

Features:

- RF Frequency: 2-20 GHz
- Small signal gain : 17.27 dB
- Output P1dB : 17.4 dBm
- DC drain bias voltage : 4 V
- Dc supply current : 140 mA
- Dc Gate Bias Voltage : -0.3 V
- 0.1um GaAs pHEMT Technology
- Die Size: 1.15 mm*2.6 mm

Functional Block Diagram

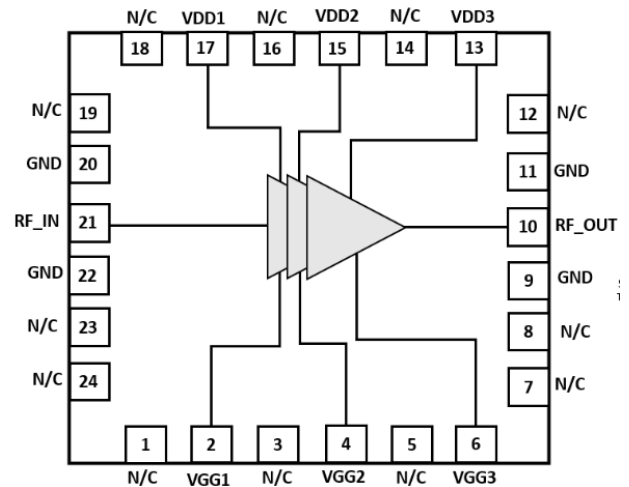

Description:

RFDA20 is Three Stage Driver Amplifier operates from 2-20GHz and it is used to drive the high-power amplifier. The Driver amplifier provides 17.27 dB of small signal gain, the input and output are matched to 50 ohms with on-chip DC blocking capacitors.

The device is specifically designed for use in 2-20 GHz. frequency in Bluetooth, Zigbee, WiFi, IoT and SATCOM Application.

The Technology used to design DA is 0.1um GaAs pHEMT Process.

Pin Configuration

Pin No.	Pin Name	Description
9,11,20,22	GND	Ground
2	VGG1	Gate Bias Voltage 1
4	VGG2	Gate Bias Voltage 2
6	VGG3	Gate Bias Voltage 3
17	VDD1	Drain Bias Voltage 1
15	VDD2	Drain Bias Voltage 2
13	VDD3	Drain Bias Voltage 3
21	RF_IN	RF Input
10	RF_OUT	RF Output
1,3,5,7,8,12,14,16,18,19,23,24	N/C	Not Connected

Applications:

- Weather radar
- Long-distance radio telecommunications
- Satellite communications
- Radar
- Automotive radar
- Astronomical observations

Deliverables:

- Sample Ready Packaged Die
- Test Results
- Product Datasheet

RFIC confidential property not to be copied or disclosed without prior authorization.

Electrical Specification:

Freq= 2 – 24 GHz, VDD1=VDD2= VDD3= 4V, VGG1=VGG2= VGG3= -0.3 V, ID= 140 mA, Zo=50 Ω

Parameters	Test Condition	Units	Typ
Gain	2 GHz	dB	14.09
	12 GHz		17.81
	24 GHz		12.42
Output P1 dB	2 GHz	dBm	
	12 GHz		17.4
	24 GHz		
OIP3 Pin= 1 dBm Δf = 50MHz	2 GHz	dBm	
	12 GHz		26.7
	24 GHz		
Noise Figure	2 GHz	dB	
	12 GHz		3.14
	24 GHz		
Input Return Loss	2 GHz	dB	2.91
	12 GHz		6.67
	24 GHz		9.7
Output Return Loss	2 GHz	dB	8.73
	12 GHz		13.84
	24 GHz		9.58
Operating Bias Conditions			
Drain Current (Id)	-	mA	140
Drain Voltage (VDD)	-	V	4
Gate Voltage (VGG)	-	V	-0.3

On Wafer Measured Performance Curve:

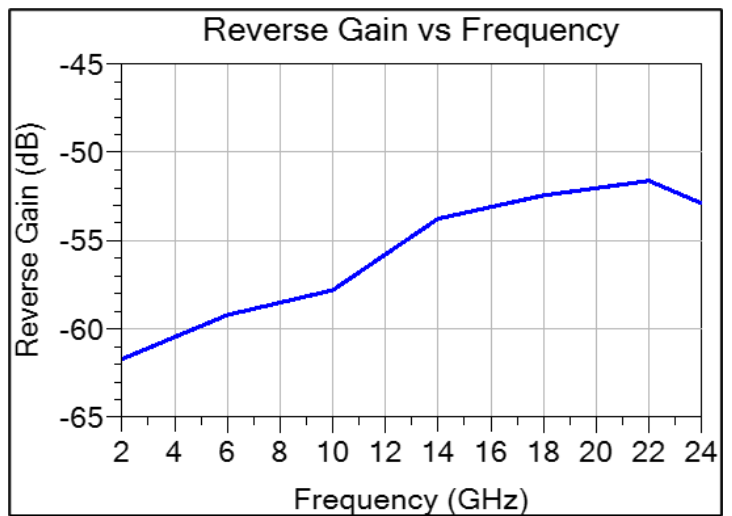
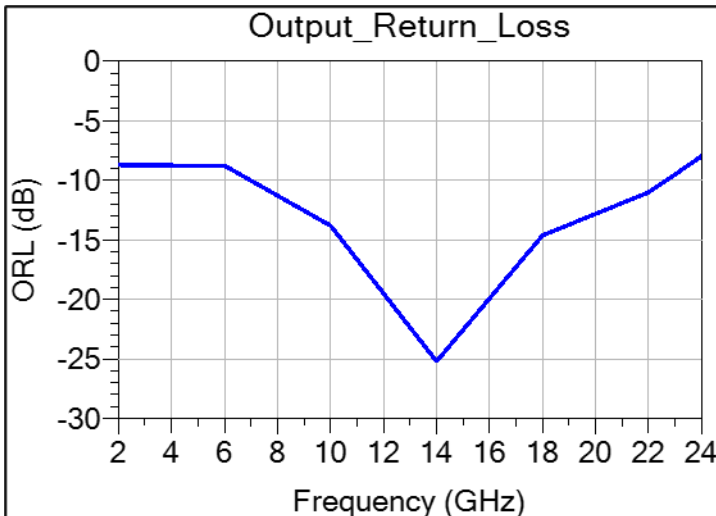
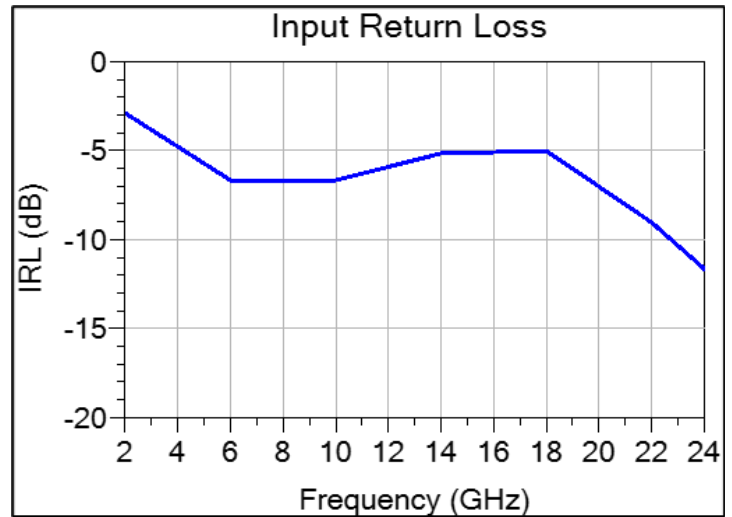
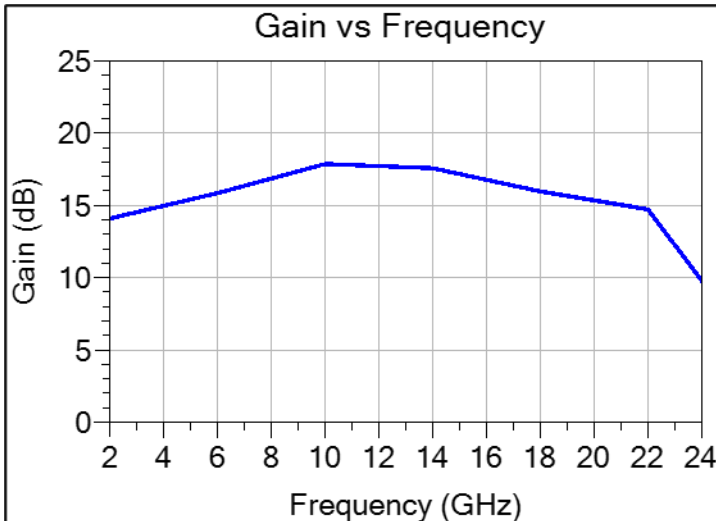

Typical Performance Curves:

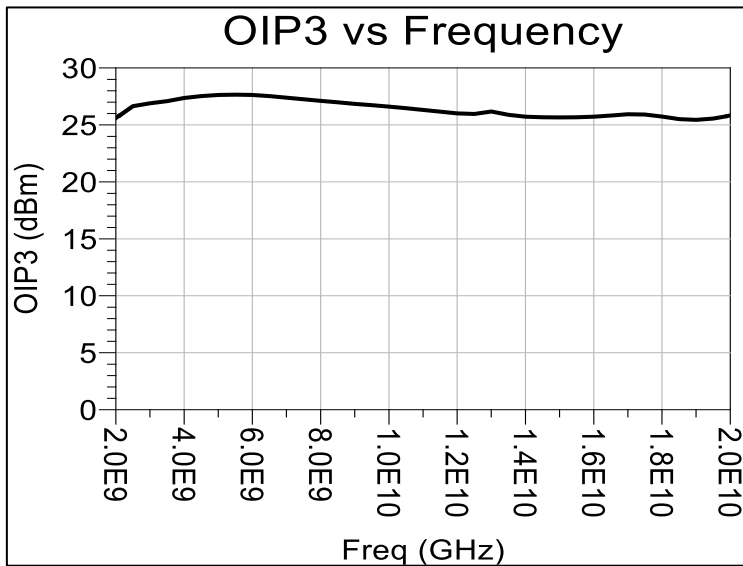
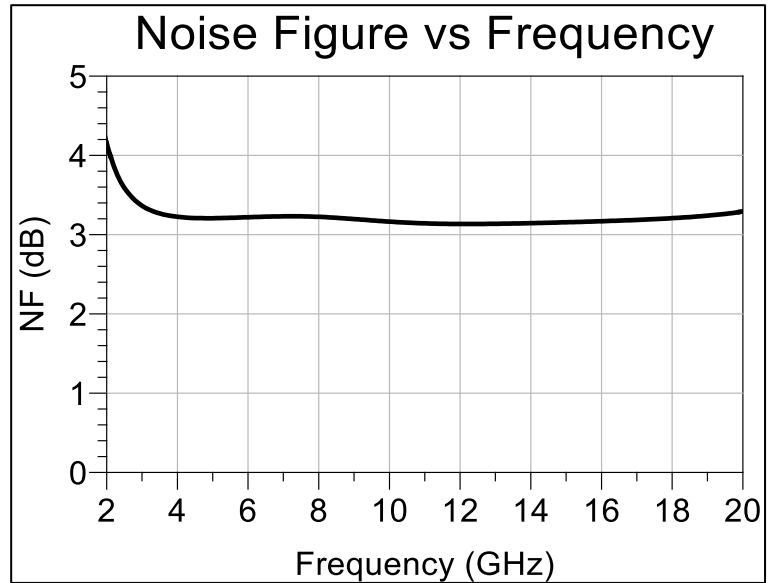
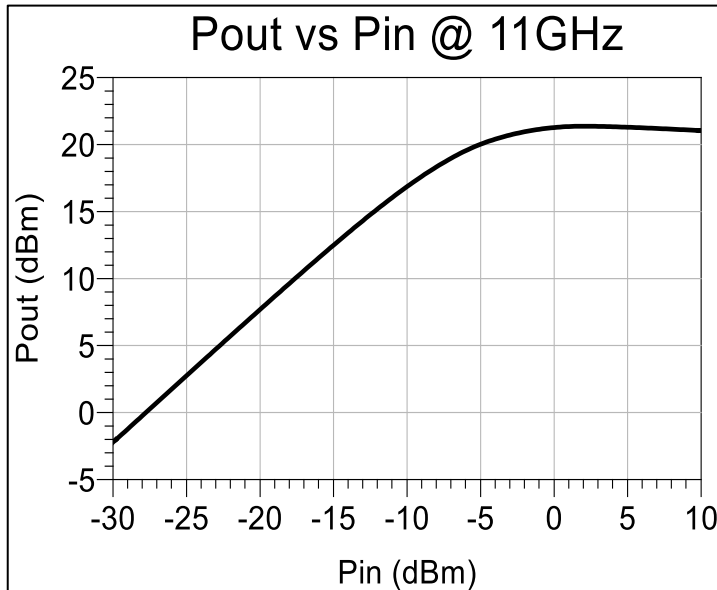

Application Diagram:

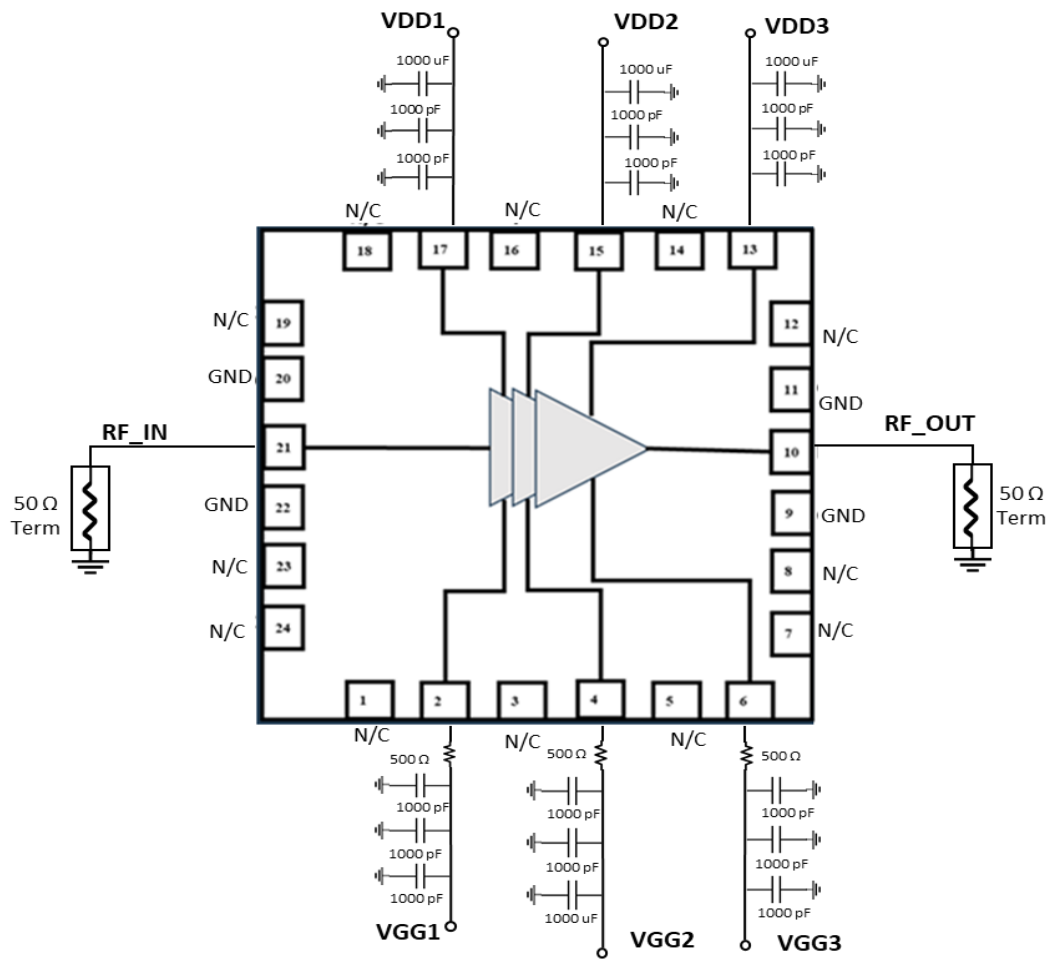

Disclaimer:

Information in this document is provided in connection with RFIC Solutions Inc. products. These materials are provided by RFIC Solutions Inc. as a service to its customers and may be used for informational purposes only. Except as provided in RFIC Solutions Inc. Terms and Conditions of Sale for such products or in any separate agreement related to this document, RFIC Solutions Inc. assumes no liability whatsoever. RFIC Solutions Inc. assumes no responsibility for errors or omissions in these materials. RFIC Solutions Inc. may make changes to specifications and product descriptions at any time, without notice. RFIC Solutions Inc. makes no commitment to update the information and shall have no responsibility whatsoever for conflicts or incompatibilities arising from future changes to its specifications and product descriptions. No license, express or implied, by estoppel or otherwise, to any intellectual property rights is granted by this document.

Contact information

For the latest specifications, additional product information:

Web: www.rficsolutions.com

Email: smoghe@rficsolutions.com

Tel: (+1) 840 356 8957, (+91)9022078131, (+91)8485841789