

# Digital Variable Attenuator

## PRODUCT DATASHEET

RFDVA07

### Features:

- RF Frequency: DC-07 GHz
- Insertion Loss: 2.22 dB, 3.22 dB, 5.82 dB, 7.69 dB
- Input Return Loss: 15.14 dB, 16.74 dB, 18.77 dB, 22.55 dB
- Output Return Loss: 14.90 dB, 12.22 dB, 16.67 dB, 14.85 dB
- Control voltage: 4 V / -4 V
- 0.1um GaAs pHEMT Technology
- Die Size: 0.9 mm\*1.45 mm

### Functional Block Diagram

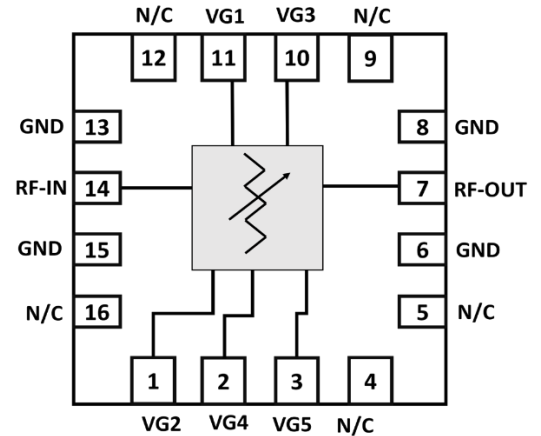

### Description:

RFDVA07 is Digital Variable Attenuator operates from DC-07 GHz and it is used to drive the Lowest insertion loss Attenuator. The Attenuator provides Insertion Loss at 0 dB, 3 dB, 6 dB, 9 dB the input and output are matched to 50 ohms with on-chip DC blocking capacitors.

The device is specifically designed for use in DC-32 GHz frequency in Bluetooth, Zigbee, WiFi, IoT and SATCOM Application.

The Technology used to design Digital Variable Attenuator is 0.1um GaAs pHEMT Process.

### Pin Configuration

Pin No.	Pin Name	Description
6,8,13,15	GND	Ground
11	VG1	Control Voltage
1	VG2	Control Voltage
10	VG3	Control Voltage
2	VG4	Bias Voltage
3	VG5	Bias Voltage
4,5,9,12,16	N/C	Not Connected
14	RF-IN	RF Input
7	RF-Out	RF Out put

### Applications:

- Military telemetry
- Radio astronomy
- GPS
- Weather radar
- Long-distance radio telecommunications

### Deliverables:

- Sample Ready Packaged Die
- Test Results
- Product Datasheet

RFIC confidential property not to be copied or disclosed without prior authorization.

### Electrical Specification:

Freq= DC – 32 GHz, VCC = 4V/-4V, Zo=50 Ω

Parameters	Frequency	Units	Typ
Insertion Loss	16 GHz	dB	2.22
			3.22
			5.82
			7.69
Input Return Loss	16 GHz	dB	15.14
			16.74
			18.77
			22.55
Output Return Loss	16 GHz	dB	14.90
			12.22
			6.67
			14.85
OIP3	4 GHz	dBm	42
IIP3	4 GHz	dBm	50
Drain Current (Id)	-	mA	—
Control Voltage (VCC)	-	V	4 / -4
Gate Voltage (VGG)	-	V	-

# Digital Variable Attenuator



## PRODUCT DATASHEET

RFDVA07

### On Wafer Testing Performance Curves:

0 dB

3 dB

6 dB

9 dB

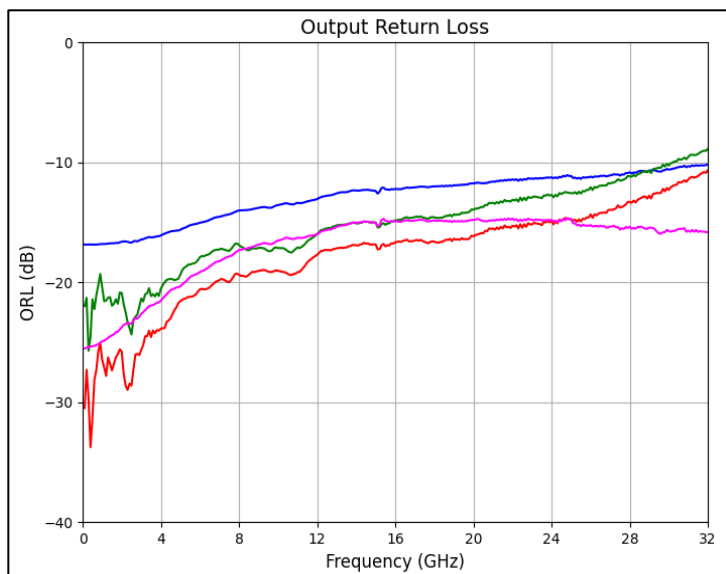
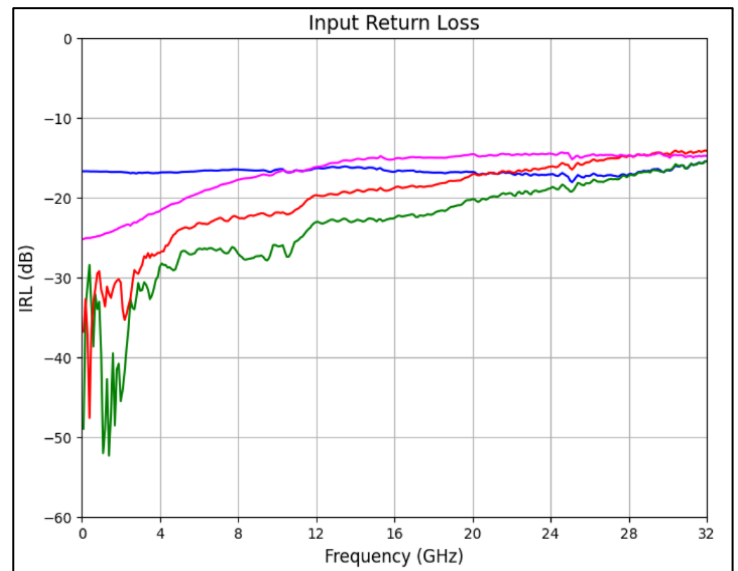
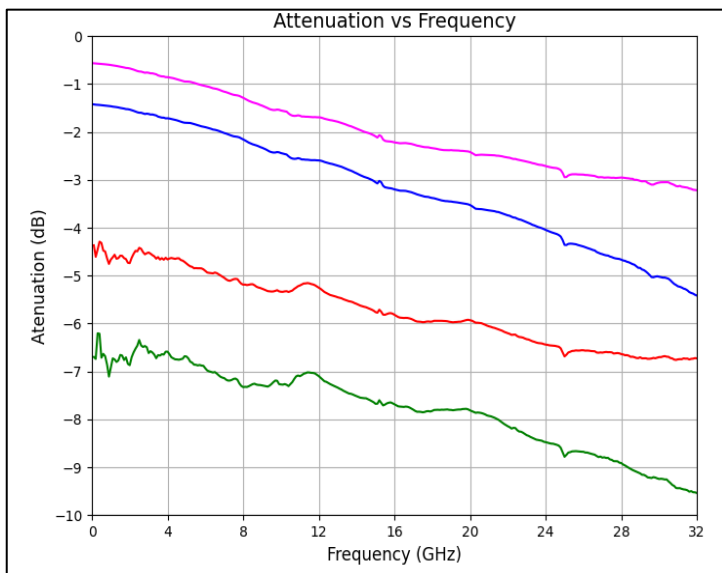

RFIC confidential property not to be copied or disclosed without prior authorization.

[www.rficsolutions.com](http://www.rficsolutions.com)

JULY 2025

### Typical Performance Curves:

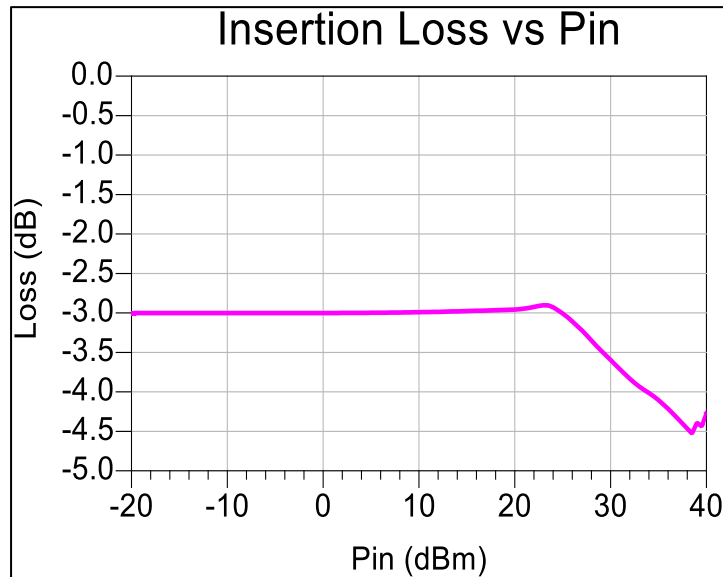
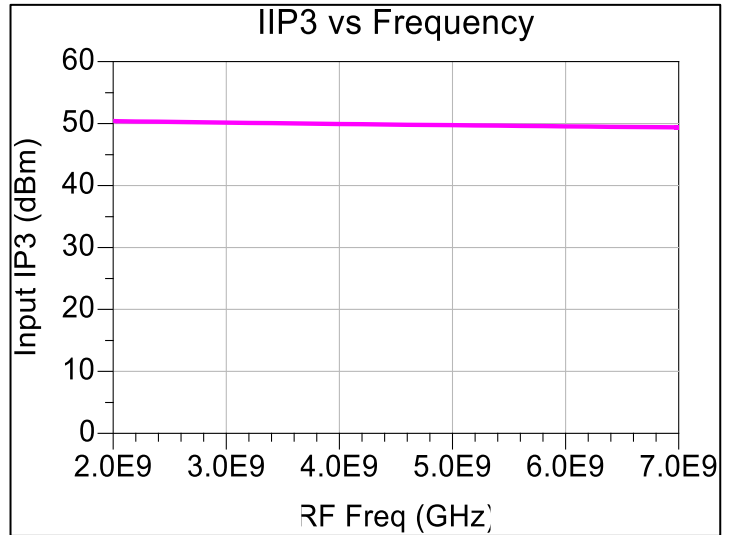
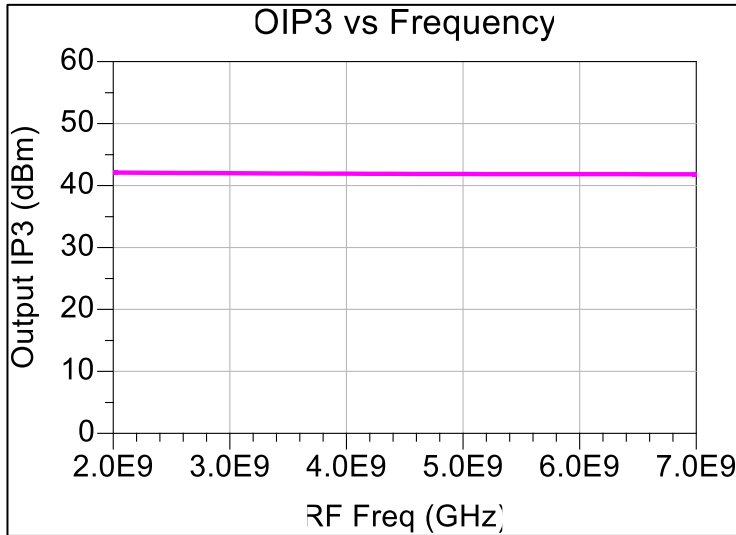

### Application Diagram:

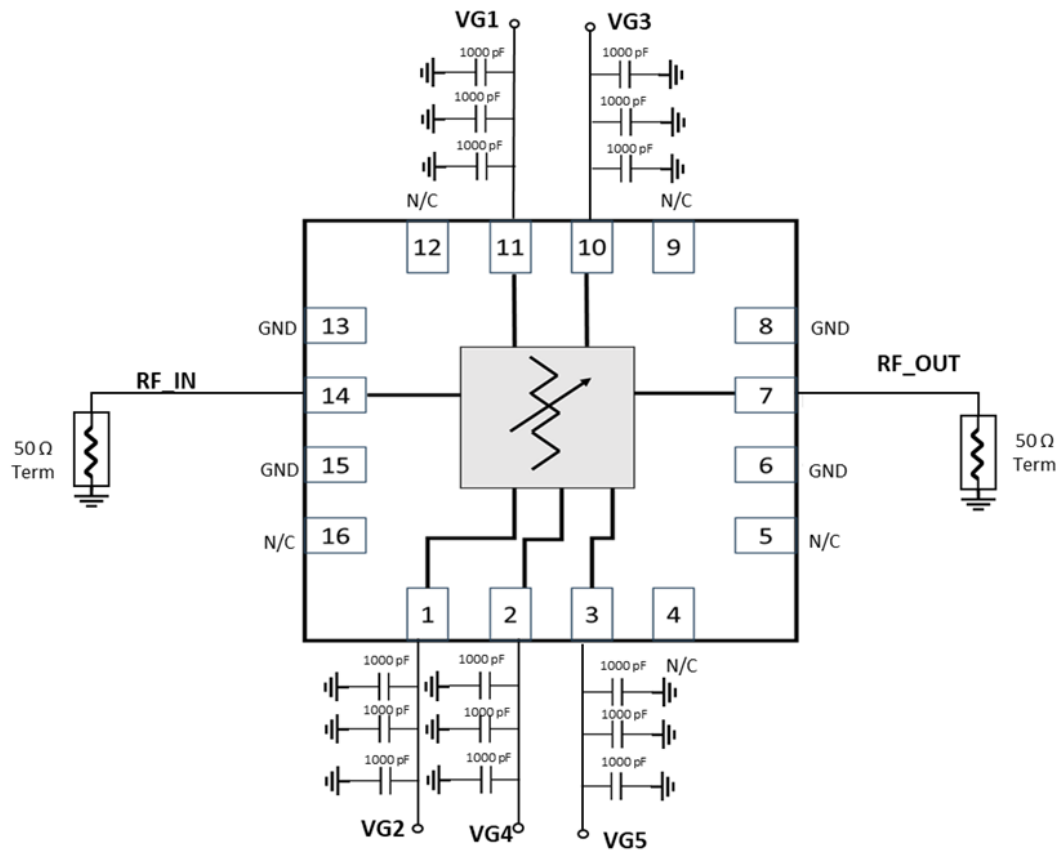

### Disclaimer:

Information in this document is provided in connection with RFIC Solutions Inc. products. These materials are provided by RFIC Solutions Inc. as a service to its customers and may be used for informational purposes only. Except as provided in RFIC Solutions Inc. Terms and Conditions of Sale for such products or in any separate agreement related to this document, RFIC Solutions Inc. assumes no liability whatsoever. RFIC Solutions Inc. assumes no responsibility for errors or omissions in these materials. RFIC Solutions Inc. may make changes to specifications and product descriptions at any time, without notice. RFIC Solutions Inc. makes no commitment to update the information and shall have no responsibility whatsoever for conflicts or incompatibilities arising from future changes to its specifications and product descriptions. No license, express or implied, by estoppel or otherwise, to any intellectual property rights is granted by this document.

### Contact information

For the latest specifications, additional product information:

Web: [www.rficsolutions.com](http://www.rficsolutions.com)

Email: [smoghe@rficsolutions.com](mailto:smoghe@rficsolutions.com)

Tel: (+1) 840 356 8957, (+91)9022078131, (+91)8485841789